

Globe valves



Pressure Seal

ASME Class 600/900

ASME Class 600 dimensional data, mm

Size inches	A		D (open)	E (closed)	ØF	Weight kg
	RF	BW				
2	292	178	405	373	254	40
3	355	254	546	508	355	80
4	431	304	685	635	457	135
6	558	457	939	876	609	275
8	660	584	1092	990	609	480
10	787	711	1270	1168	609	780
12	838	812	—	1570	609	1150

10 inches and smaller manually operated
Weights of raised flange valve style
Dimensional data of greater sizes upon request

ASME Class 900 dimensional data, mm

Size inches	A		D (open)	E (closed)	ØF	Weight kg
	RF	BW				
2	368	—	501	458	310	55
3	381	304	685	635	355	105
4	457	355	838	774	508	170
6	609	508	1143	1066	508	370
8	736	660	1422	1333	609	720
10	838	787	—	1574	609	1200

8 inches and smaller manually operated
Weights of raised flange valve style
Dimensional data of greater sizes upon request

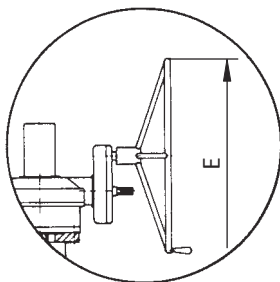
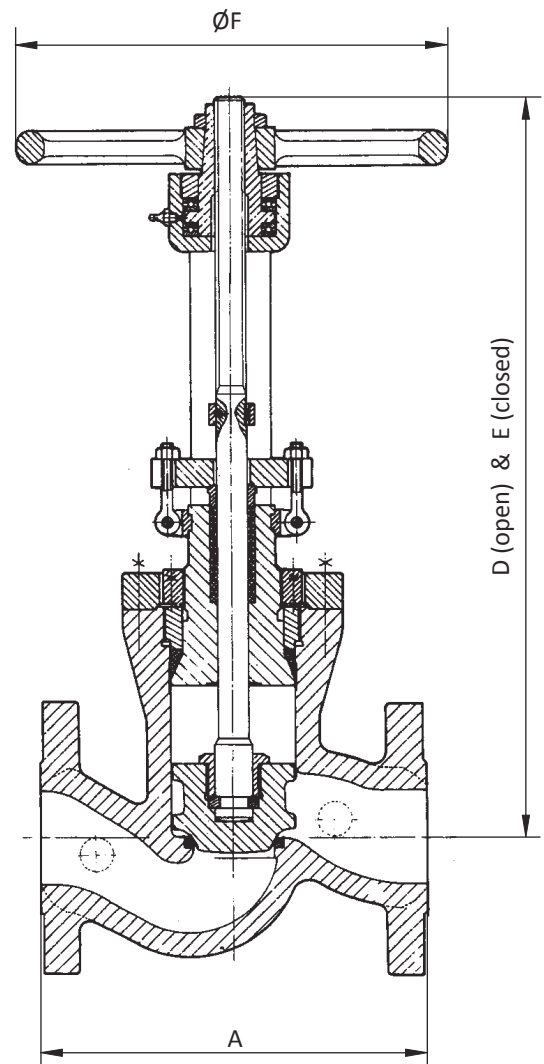

Pressure Seal

ASME Class 1500/2500

ASME Class 1500 dimensional data, mm

Size inches	A BW	D (open)	E (closed)	$\varnothing F$	Weight kg
2	368	501	458	310	55
3	469	685	635	355	95
4	546	838	774	457	155
6	704	1193	1092	609	400
8	831	—	1496	508	640
10	990	—	1549	609	1200

6 inches and smaller manually operated
Dimensional data of greater sizes upon request

ASME Class 2500 dimensional data, mm

Size inches	A BW	D (open)	E (closed)	$\varnothing F$	Weight kg
2	451	500	458	310	71
3	578	680	662	355	125
4	673	755	716	457	201
6	914	1040	980	609	520
8	1022	—	1158	508	832
10	1270	—	1420	609	1560

6 inches and smaller manually operated
Dimensional data of greater sizes upon request

